

Christmas Ornament Display Structure

Team 7:

Dolores Gallardo

Ryan Palmer

Miles Roux



Retrieved from mystarofbethlehem.com/home

Northern Arizona University
Department of Mechanical Engineering

Overview

- Client background
- Final Design
- Manufacturing
- Cost analysis
- Project timeline
- Conclusion
- References

Client Background

- My Star of Bethlehem LLC
- Online business
- Based in Sedona, AZ
- Import and sell decorative stars manufactured in Germany
- Need an aesthetically pleasing way to display their products when promoting at multiple venues

Final Design

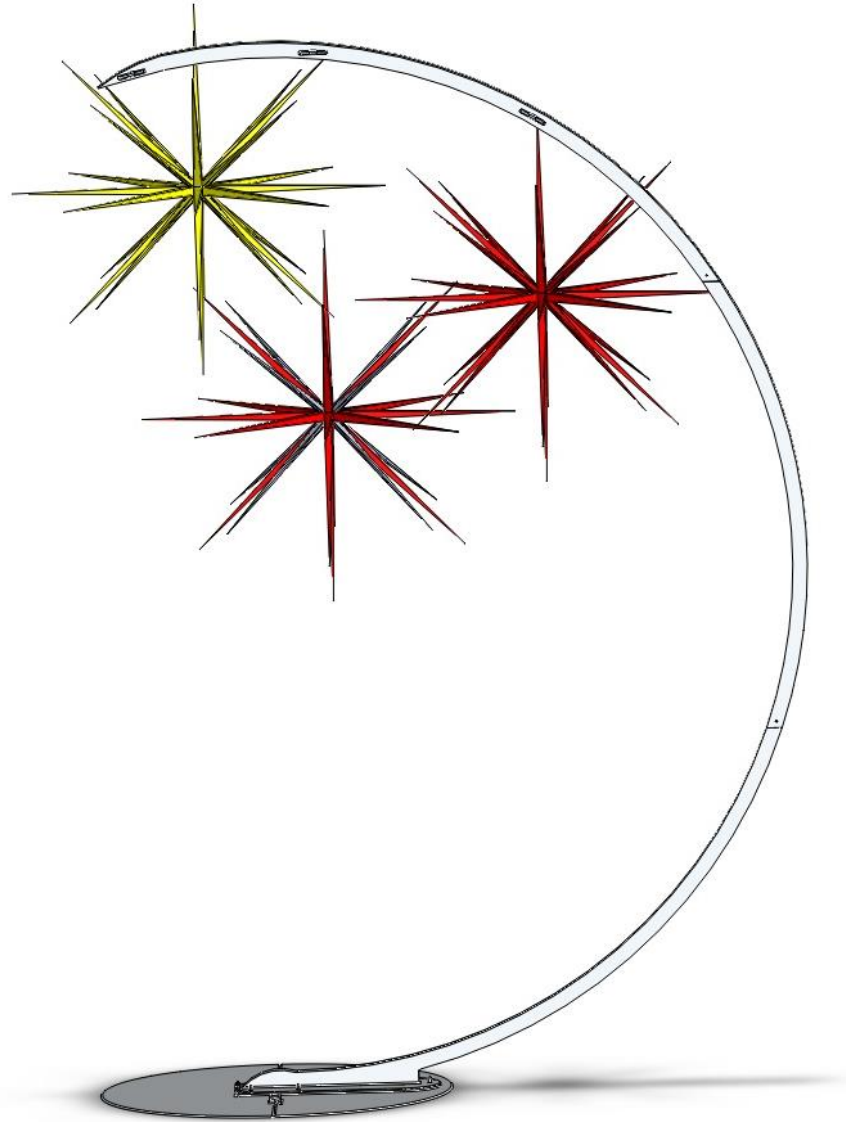

Base With Hinge Plate

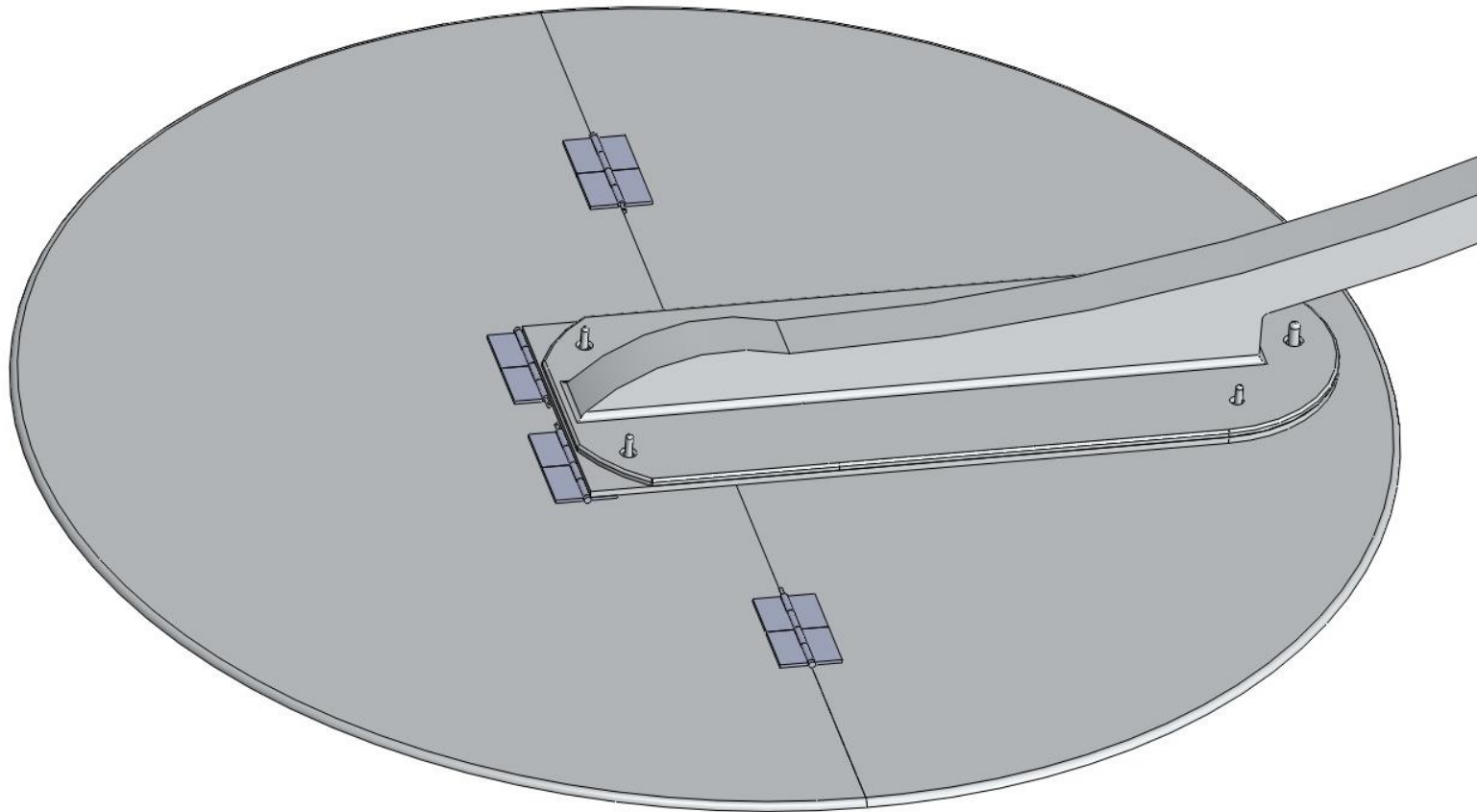

Exploded Views

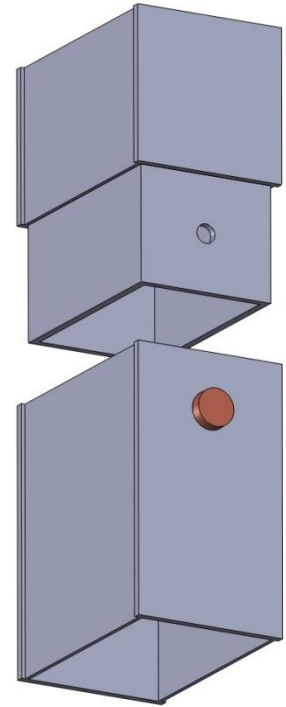
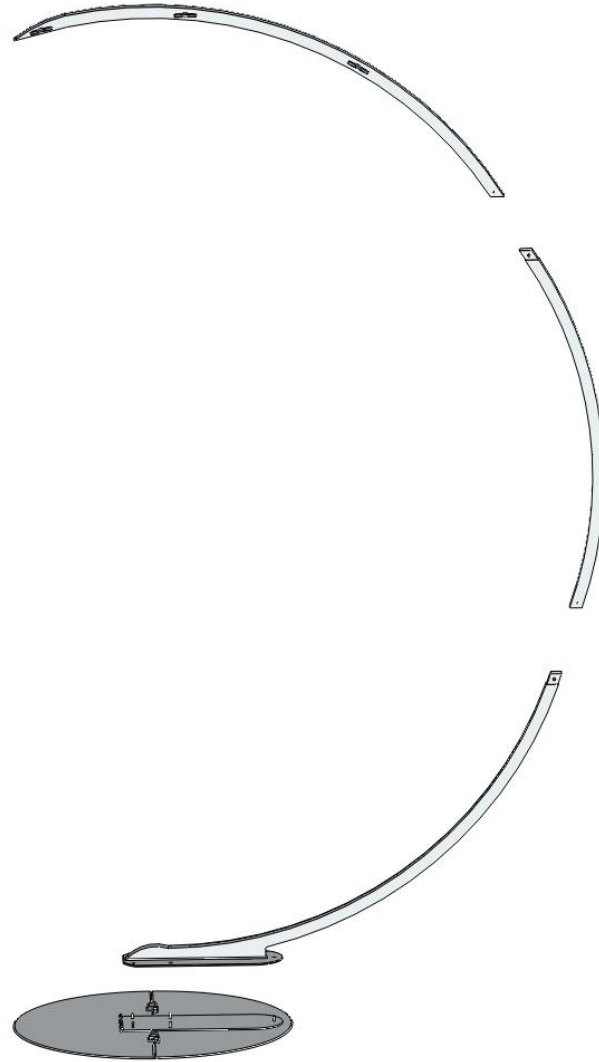
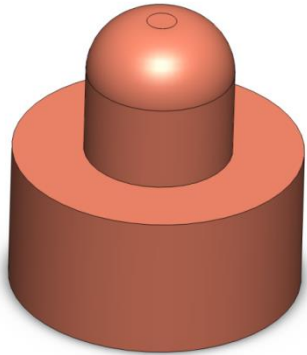
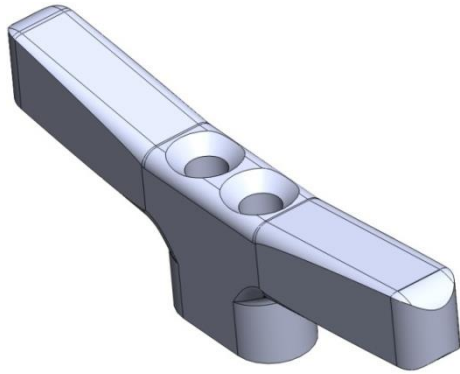

Without Lanyard

Retrieved from
<http://www.mcmaster.com/#>

Middle Arch Section

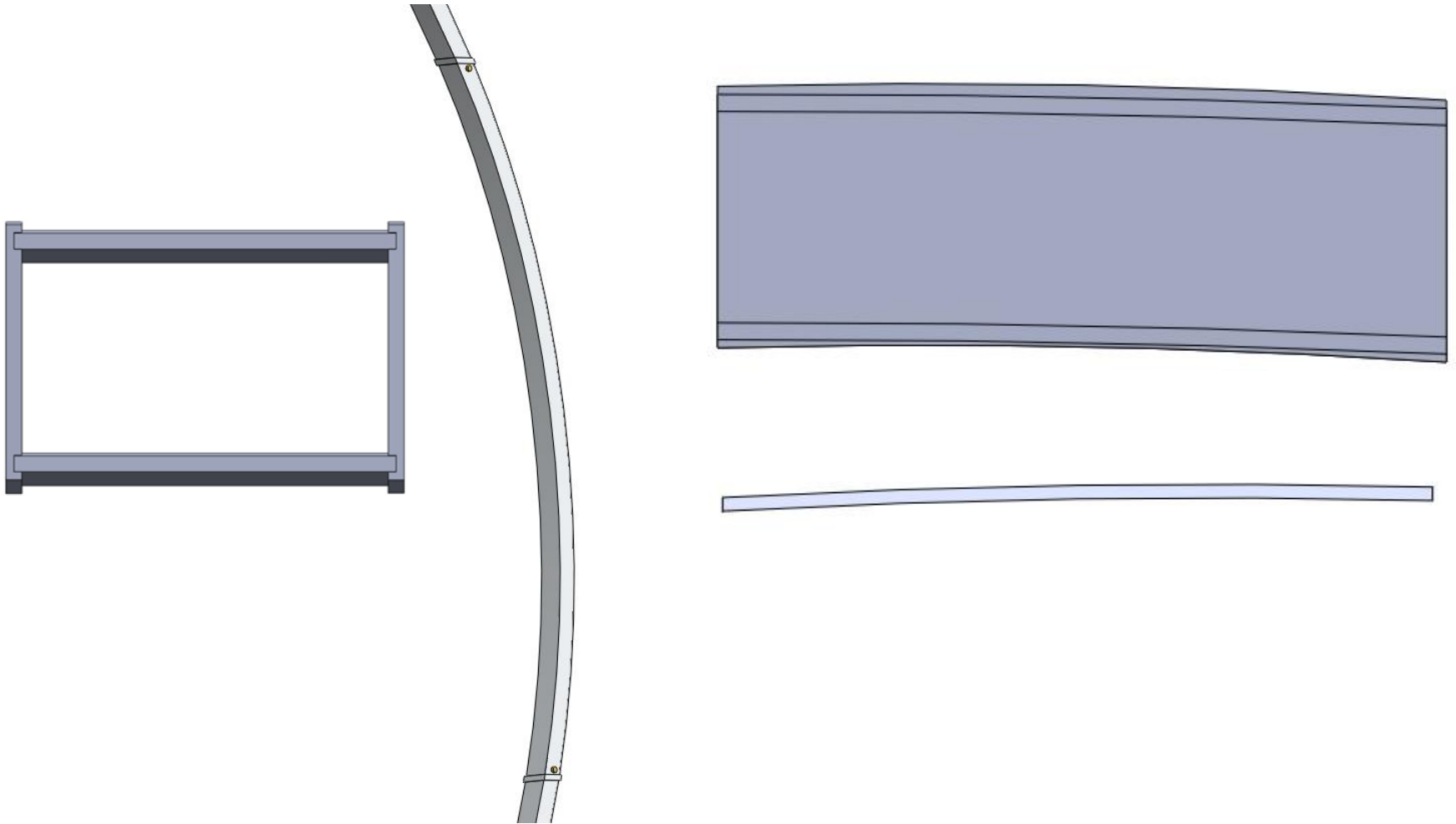

Completed So Far

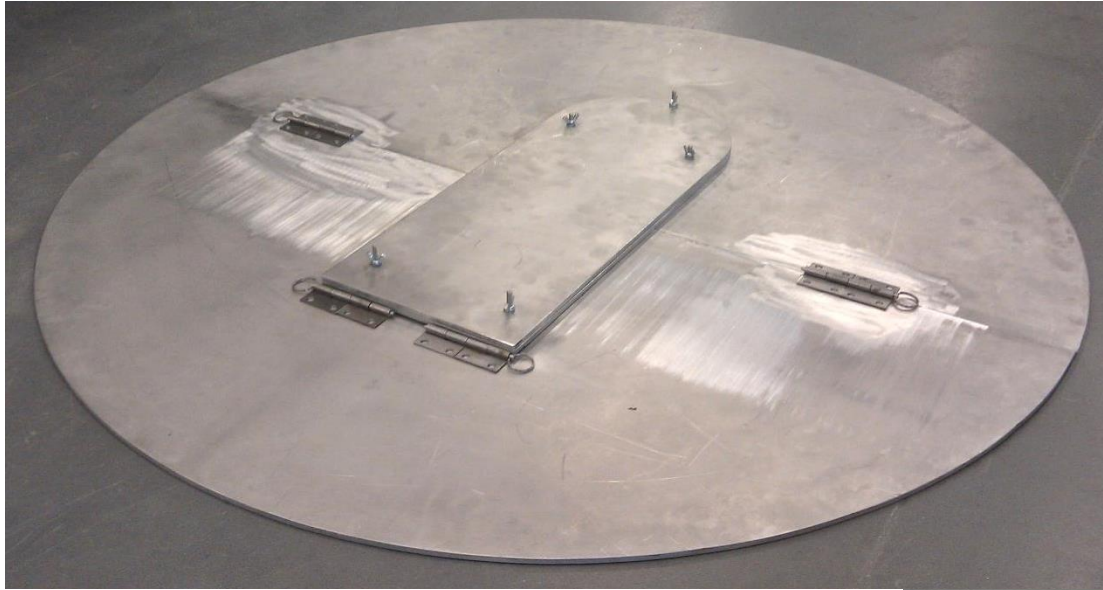

Cost Analysis

Qty	Item Description	Size (w x t)	Length	Price (each)	Total Cost
1	6061-T6 Aluminum Sheet	48 x 0.13	144	\$295.80	\$295.80
2	6061-T6 Aluminum Plate	24 x 0.25	48	\$115.55	\$231.10
2	6061-T6 Aluminum Plate	24 x 48 x 0.25	24	\$62.65	\$125.30
		Size (D)			
4	18-8 Stainless Steel Quick Release Pin	0.19 (pin)	3	\$2.18	\$8.72
4	Retractable Captive Panel Plunger Press in	0.25 (pin)	0.75	\$4.12	\$16.48
6	Surface-Mounted Lift-Off Hinge without holes	0.19 (pin)	2	\$3.56	\$21.36
6	Rope Cleat Wing Style	0.25 (rope)	3.5	\$0.92	\$5.52
1	Press-In Captive Stud 18-8 Stainless Steel (Pack of 10)	0.25	1.5	\$9.26	\$9.26
	Fasteners, quick release pins, adhesive, hinges, drill bits etc.				\$280.50
				Sales Tax	\$60.65
				Shipping	\$73.50
				Final Cost	\$1128.19
All dimensions are in inches					
w = width, t = thickness, D = diameter					
Sales tax only applies to products bought in Arizona					

Project Timeline

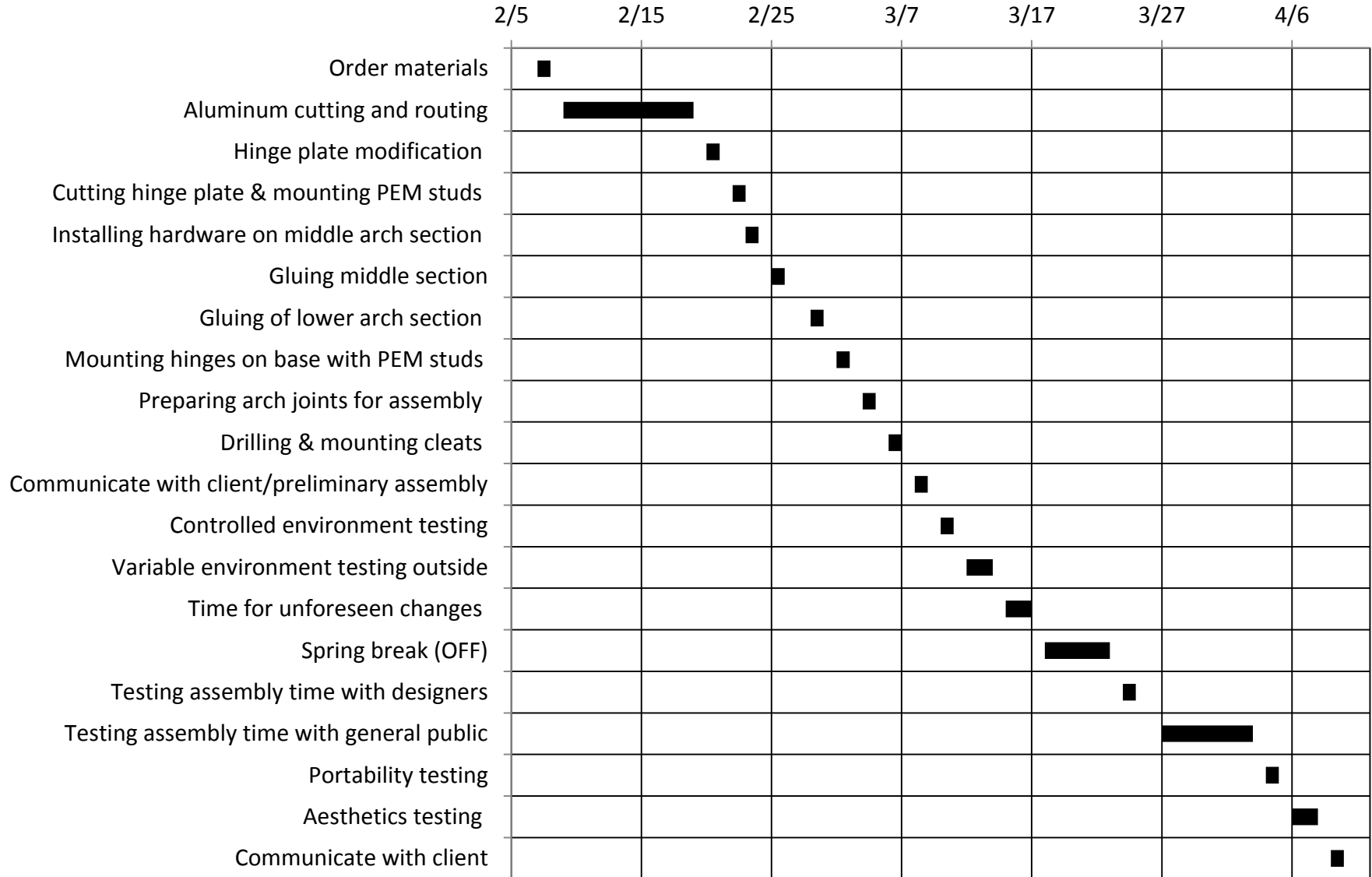

Conclusion

- Client Background
 - My Star of Bethlehem LLC
 - Small online business
 - Based in Sedona, AZ
- Final design
 - Modifications – studs moved back & collars
- Manufacturing
 - Arch sections – gluing instead of welding
 - Hinges – fastening instead of welding
- Cost analysis
 - Costs have increased \$280
- Project timeline
 - Changes made
 - Future tasks

References

- [1] Dr. Dieter Otte
Assistant Professor of Computer Science
Department of Electrical Engineering/Computer Science
CEFNS at Northern Arizona University
Phone: 928-523-0876
Email: Dieter.Otte@nau.edu
- [2] McMaster-Carr. (n.d.). *McMaster-Carr*.
Retrieved from <http://www.mcmaster.com/#>
- [3] Industrial Metal Supply Co. (2010). *Industrial Metal Supply Co.*
Retrieved from <http://www.industrialmetalsupply.com/>

Questions

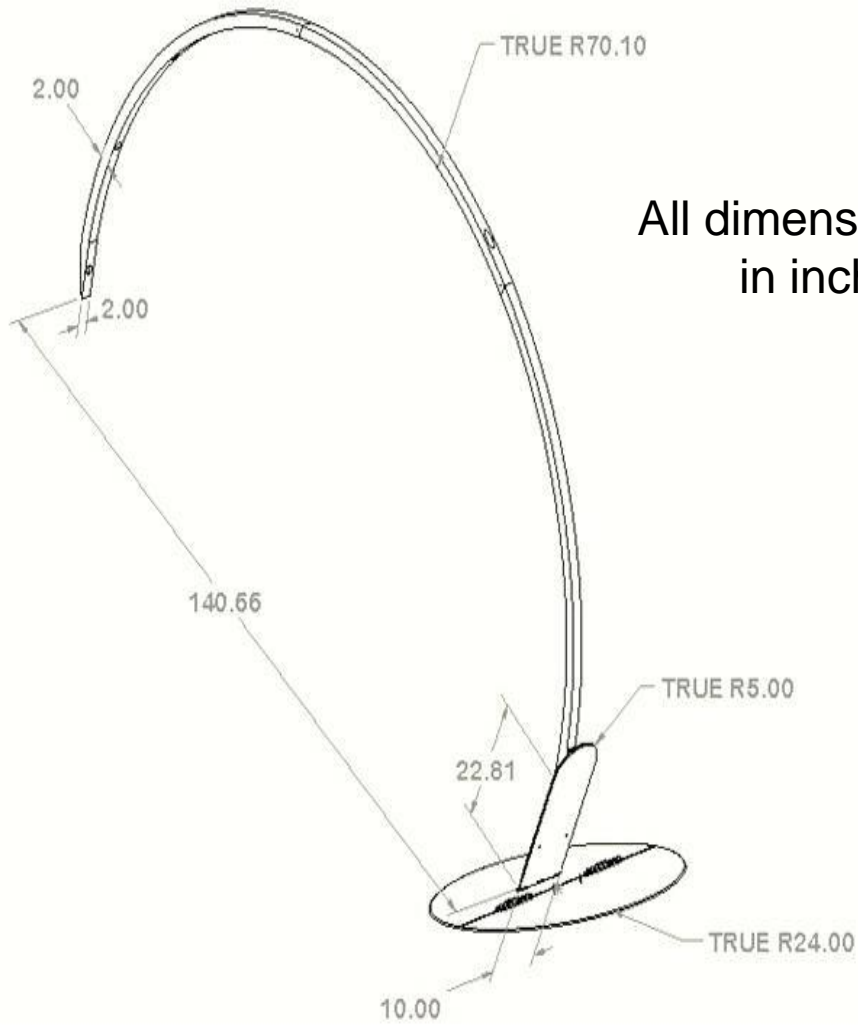

All dimensions are
in inches

